



SYSTEM TB 500

BULK ADHESIVE APPLICATOR

INSTRUCTION FOR SET UP AND OPERATION

TEKMARTM
TECHNICAL MARKETING, LTD.



SYSTEM TB 500

Congratulations on your purchase of the TARGET SYSTEM TB 500 Bulk Adhesive Applicator. This high quality spray system is designed to operate continuously providing years of trouble free service, requiring only minimal maintenance. When used with TEKBOND TB-10 water based adhesive it is the perfect, safe and environmentally responsible replacement for aerosol spray tack.

The system is extremely durable and will provide years of trouble free operation. The only required maintenance for the system is regular cleaning. This is outlined in the care and maintenance section of this manual. The biggest single cause of premature failure of this system results from insufficient cleaning, so please pay extra attention to this section.

As with all TARGET or TEKMAR products, should you experience any difficulties with this product please call our customer service line at

800/564-1096

AIR HOOK UP

The air requirements for the SYSTEM TB 1000 are very minimal. An input pressure of 40-60 PSI is all that is required. The MAXIMUM input pressure for the system is 60 PSI.

2.0 It is highly recommended that the air be attached to the unit using a quick release connector. This allows the air to be easily disconnected for maintenance or in the event of an emergency.

INITIAL SET UP AND ADJUSTMENT

The success of the TEKBOND adhesive system is reliant on the use of TB10 water base adhesives. substitutions. may result in inferior operation and may invalidate the warranty

Getting Ready

3.0 Prepare the bucket of TB 10 by cutting the opening where shown on the lid

3.1 Slide the TB500 onto the bucket and attach the latches to the sockets on the side of the bucket.

3.2 Connect the air line to the unit and adjust the inlet pressure to 40-45 psi. The pump should cycle

3.3 The spray gun has two adjustment controls. The smaller knob is the spray adjustment control, while the larger knob controls the flow. Open up the larger knob 2 or 3 turns (counter-clockwise) to allow the system to prime. Directing the gun into a trash can or old cardboard box, squeeze the trigger all the way in and hold it until adhesive starts to come out of the nozzle.

3.4 As soon as adhesive is spraying out of the nozzle, release the trigger and rotate the knob back in (clockwise) until it stops. Squeezing the trigger, slowly rotate the large knob until a fine spray is achieved. The desired setting should produce an extremely fine spray pattern that is almost invisible.

3.5

3.6

3.7

3.8 The smaller silver knob on the gun is used to adjust the spray pattern. With the knob all the way in a circular spray pattern is achieved (see fig a). By slowly rotating it counter clockwise a flatter fan type spray pattern can be achieved (see fig b). The flat fan spray pattern is more suitable for the application of adhesive. The nozzle should be positioned vertically to produce horizontal flat fan or reversed for a vertical spray.

a

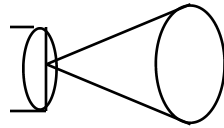

Fig a.

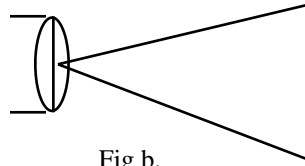

Fig b.

3.9 If more adhesive is required then slowly turn the lower, larger silver knob counter-clockwise. Once the desired spray has been set, practice spraying on some scrap cardboard.

3.91 An additional adjustment ring is located at the front of the gun behind the nozzle. This can be rotated to widen or narrow the spray pattern

3.95 The unit should be located as near to the press as possible. It should be placed in an area where it will not be knocked over as this could result in damage to the unit.

OPERATION

The success of the TARGET SYSTEM TB 500 and TEKBOND TB-10 is dependent upon the minimal use of the adhesive. To maximize adhesive usage it is essential to follow the operating procedures outlined below.

4.0 Initially when starting with clean pallets it is necessary to apply a “build” of adhesive before printing, this is a very quick operation. Simply apply a very light application of adhesive, 2 or 3 fast passes moving from the front to the back or from side to side of the pallet is all it takes. Rotate through each pallet twice. This will only take a few minutes and will allow a good base for the adhesive to “build” on.

4.1 Start printing as usual, apply a fine mist of adhesive as required. If lint starts to gather on the pallet, it can quickly be removed using a slightly damp sponge. Often it is not necessary to re-apply adhesive after this lint removal procedure. When sprayed in the above manner, TEKBOND TB-10 should tack almost instantly allowing high speed loading and unloading of textiles.

4.2 As printing continues re-apply adhesive as necessary. Do not over apply adhesive as it will start lay down too thick and will then have potential to start transferring onto the garment.

4.3 On fleece goods adhesive will need to be applied more frequently due to the transfer of fleece onto the pallet.

4.4 *It is highly recommended that pallet mask be used to eliminate unnecessary clean-up*

CARE AND MAINTENANCE

Cleaning

The biggest single cause for premature failure of the TB500 is as a result of insufficient or non cleaning of the pump and spray gun. If the following steps are taken then the unit will provide years of trouble free maintenance

If the unit is to be inactive for any period of time (2 or more days) or at least once a month the unit should be flushed in the following manner.

Do not use paint strippers as this will harm system. Do not allow the unit to lay on it's side while
, as this can allow adhesive to leak out of the bucket.

NOTE : Wet adhesive can be washed off the system using hot water. Should it be allowed to dry, then an adhesive remover such as TB-AR will have to be used

5.0 Once a day, at the end of the shift, the nozzle on the spray gun should be wiped clean of adhesive using TEKBOND TB-AR adhesive remover. Special care should be taken to ensure that the small air holes are not blocked as the will effect the atomization of the adhesive. If they are heavily clogged with adhesive then the nozzle should be removed and allowed to soak in TB-AR remover.

5.1 Once a month or as needed the system should be flushed. This is very simple. Remove the pump from the bucket. Wipe the tube off with a rag soaked in warm water or with TB-AR.

5.2 Place approx. 1 qt of warm water in the cleaning bucket.

5.3 Trigger the gun and allow water to flow into a container until it flows clear.

5.4 Remove water, and repeat with TBAR or De-natured Alcohol Then clean fluid nozzle (591-01) and air cap (591-02). If any dirt appears in orifice' clean with tooth pick; wire will damage nozzle. Blow nozzle and cup dry. Replace nozzle and cover loosely.

Maintenance:

6.1 General maintenance guides include regular flushing of the pump and keeping the air cap holes clean.

6.2 Needle wear is not unusual. To identify this problem, look for wear of the tip and wear between the needle and the point of contact with the packing. To replace needle, remove adjusting screw. Be careful when removing adjusting screw as it is spring loaded! Pull trigger back all the way and grasp end of needle. Let trigger go without letting needle loose. Pull needle from gun. Re-assemble needle cap and lock nut with replacement needle. Re-insert into gun and adjusting screw.

Lubrication

Lubrication procedures should be initiated on a regular basis, at least weekly, using a non-silicon spray gun lube.

7.1 Lubricate the exposed parts of the needle (591-20) in front of and behind the trigger (591-43).

PARTS DRAWING

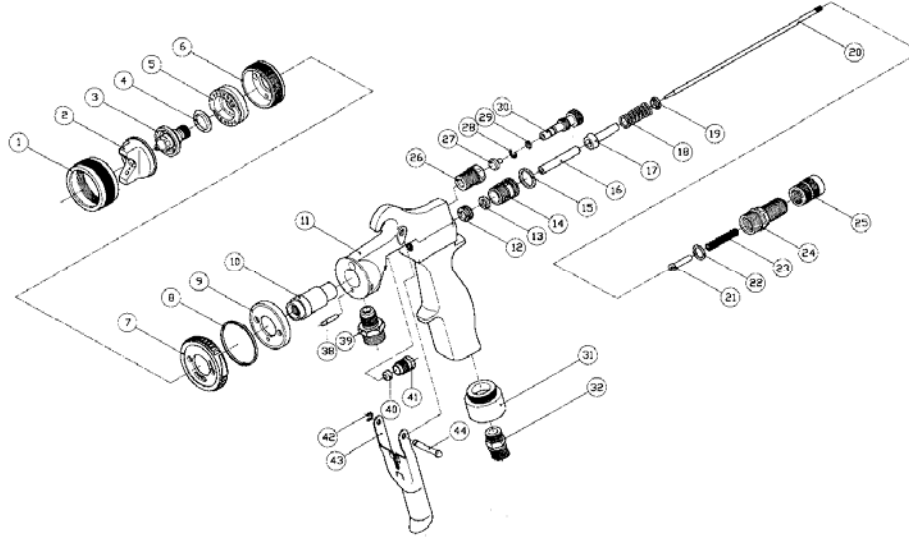

PARTS LIST

Item	Part	Description
1	591-01	Retaining Ring
2	591-02	Air Cap
3	591-03	Fluid Nozzle
4	591-04	Gasket
5	591-05	Air Ring
6	591-06	Lock Screw
7	591-07	Side Port Contl.
8	591-08	"O" Ring
9	591-09	Platen
10	591-10	Adapter Assy.
11	591-11	Gun Body
12	591-12	Lock Nut
13	591-13	"O" Ring
14	591-14	Bushing
15	591-15	"O" Ring
16	591-16	Pin Pusher
17	591-17	Pilot Valve
18	591-18	Spring
19	591-19	Washer
20	591-20	Fluid Needle

Item	Part	Description
21	591-21	Fluid Screw
22	591-22	"O" Ring
23	591-23	Spring
24	591-24	Bushing
25	591-25	Adjusting Screw
26	591-26	Bushing
27	591-27	Air Restrictor
28	591-28	Retaining Ring
29	591-29	"O" Ring
30	591-30	Adjusting Screw
38	591-38	Dowel Pin
39	591-39	Fluid Connector
40	591-40	Packing
41	591-41	Packing Screw
42	591-42	Retaing Ring
43	591-43	Trigger
44	591-44	Stud

This page left blank intentionally

This page left blank intentionally

LIMITED LIFETIME WARRANTY

Technical Marketing, Ltd. makes every effort to ensure that its products meet high quality and durability standards, and warrants to the original purchaser that this product meets high quality and durability standards, and warrants to the original purchaser, for a period of 1 year from date of purchase, that this product is free from defects in materials and workmanship, that all components of this adhesive system are free from defects in materials and workmanship. Additionally for the effective life of the product any labor resulting from repair of the equipment will be at no charge to the owner, provided that the following terms and conditions are complied with. This warranty does not apply to damage due directly or indirectly to misuse, abuse, negligence or accident' repairs or alterations outside our facilities, or to lack of maintenance. We shall in no event be liable for death, injuries to persons or property, or for incidental, contingent, special, or consequential damages arising from the use of this product. Some states do not allow the exclusion or limitation of incidental or consequential damages, so the above limitation of exclusion may not apply to you.

To take advantage of this warranty, the product or part must be returned to us with transportation charges prepaid. Proof of purchase date and an explanation of the complaint must accompany the product. If our inspection verifies the defect, we will either repair or replace the product at our election, or we may elect to refund the purchase price if we cannot readily and quickly provide you with a replacement. If we determine there is no defect, or that the defect resulted from causes not within the scope of this warranty, then you must bear our costs in storing and returning the product.

Specifically excluded from this warranty are failures caused by misuse, neglect, abuse, improper operation or modification, or unauthorized service or parts. Technical Marketing, Ltd. will not be liable for consequen-

TEKMAR™
TECHNICAL MARKETING, LTD.

CUSTOMER LINE: 800/564-1096 • PHONE: 805/965-0704

FAX: 805/963-7794

www.tekmarltd.com

SHIPPING

927 INDIO MUERTO ST.
SANTA BARBARA, CA 93103

MAILING

P.O. BOX 4700
SANTA BARBARA, CA 93140